

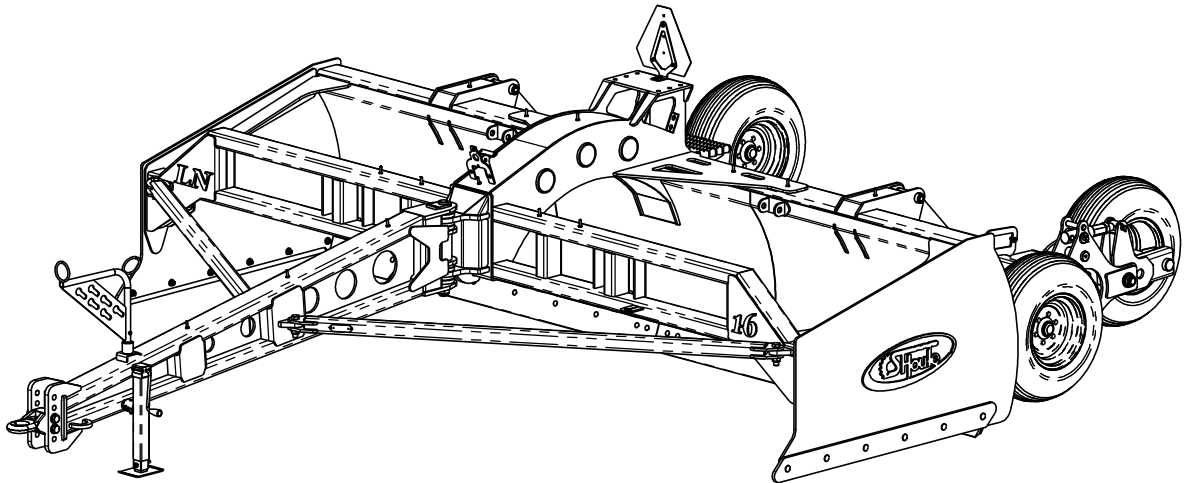

# PARTS MANUAL



CAT # N0216-60004

**LAND LEVELER LN-16 STD**  
**N0216-00004**



LAND LEVELER LN-16 STD  
N0216-00004

TECHNICAL SHEET

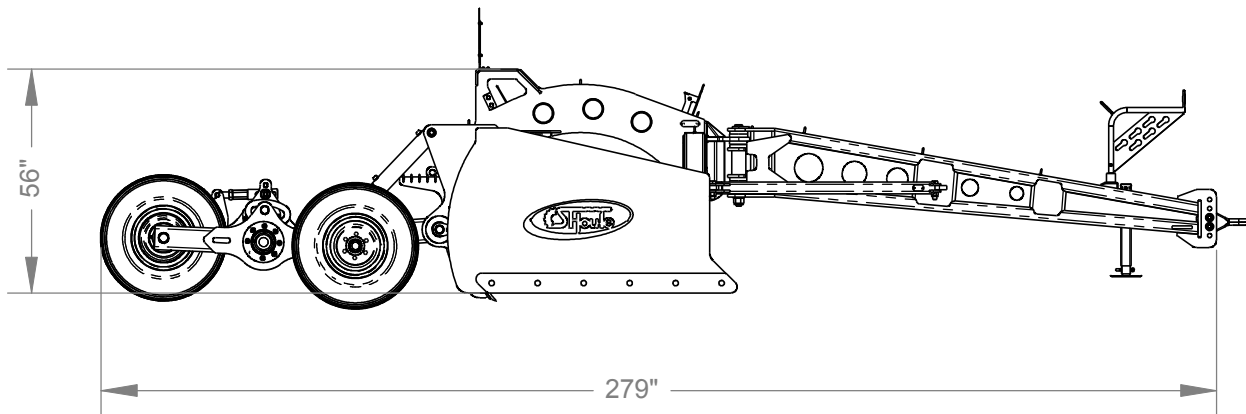
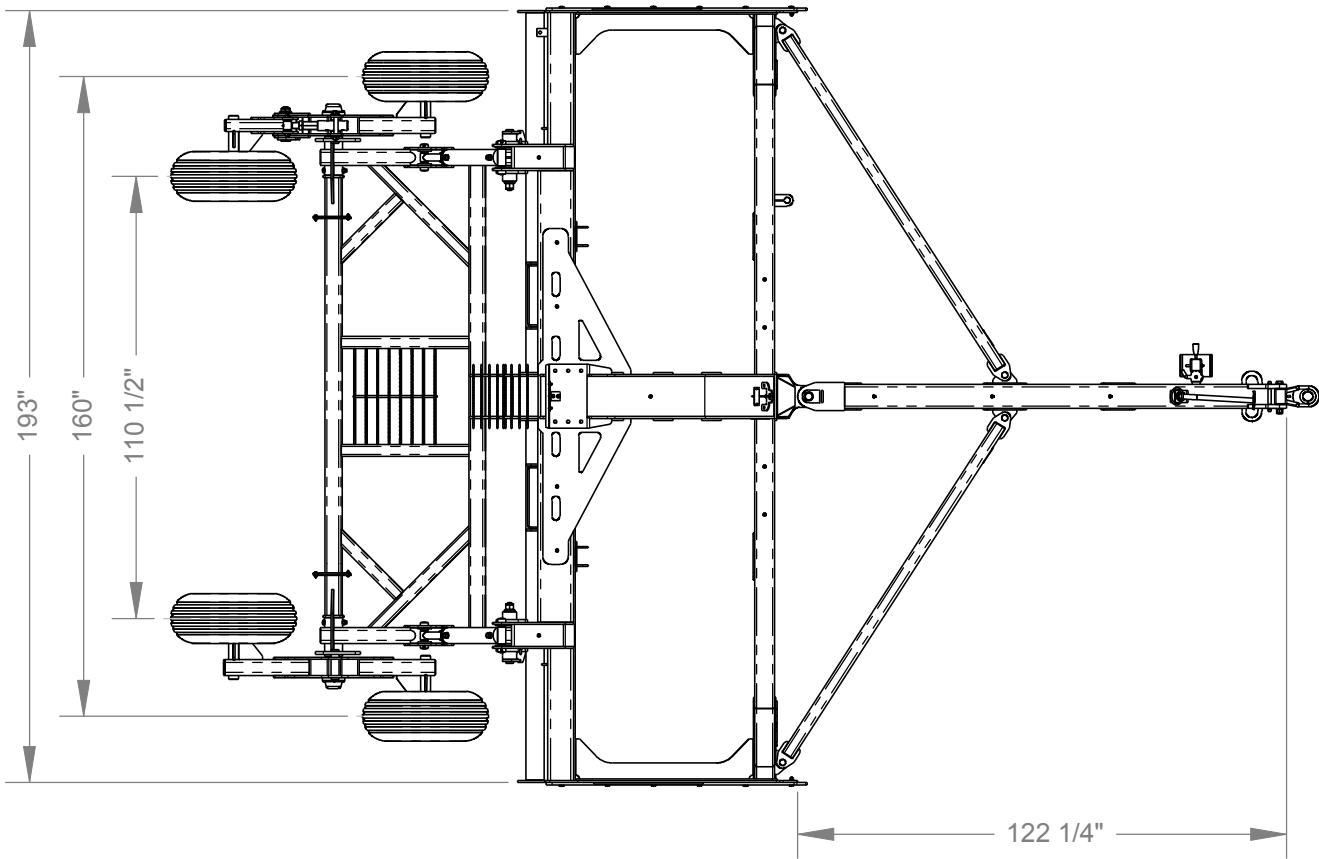

LAND LEVELER LN-16 STANDARD ILLUSTRATED

APPROX. WEIGHT : 8400 LBS



## *Locate this symbol – it could save your life*

This symbol is the standard safety symbol. You will find it on most of the decals on your equipment. It is also used throughout this manual.

This symbol is used mainly to draw your attention and to warn you of possible dangers and/or potential injuries.



**It is vital that you read and understand completely the following instructions and safety rules prior to using your equipment.**



The safety symbol accompanied by the word “ DANGER” indicates an immediate danger capable of causing serious injury or death.



The safety symbol accompanied by the word “ WARNING” indicates a potential danger capable of causing serious injury or death.



The safety symbol accompanied by the word “ CAUTION” indicates a potential danger capable of causing injury.

Being well informed is your best protection against accidents! It is therefore important that you give particular attention to the safety guidelines presented in this manual.

**Think SAFETY! Work SAFELY!**



As the owner of this equipment, you are responsible for the safety of its users and those who are responsible for its maintenance! You and any other person using or performing maintenance on this equipment must be familiar with its operation and maintenance, as well as the safety measures contained in this manual. Having safe working practices guarantees a safer work environment.

The owner of this equipment must inform any user of all instructions related to proper operation and use of this equipment, prior to first use.

The user must read, understand and respect all operating and safety instructions contained in this manual. A user who is unaware or ignores the operating and safety instructions contained herein is not qualified to operate this equipment, and exposes him/herself and bystanders to possible serious injury and or death.

Do not in any way modify this equipment. Unauthorized modifications could impair the proper functioning and/or safety of this equipment and possibly affect its useful life as well.

### **General Safety Measures**

- 1) Read and understand all operating and safety instructions and guidelines contained in this manual prior to using, maintaining or adjusting the equipment.
- 2) Ensure all safety guards and shields are properly installed prior to using the equipment.
- 3) Always have a first aid kit within reach, and know how to use it.
- 4) Always have a fire extinguisher within reach, and know how to use it.
- 5) Wear appropriate safety gear, such as: hard hat, safety boots, safety goggles, gloves, ear plugs, etc.
- 6) Clear the area of people, especially children, prior to engaging the equipment.



- 1† Lower the land leveler, stop the tractor' s engine, set controls to neutral, engage the emergency brake, remove the tractor' s ignition key and wait for all moving parts to come to a full stop prior to adjusting, detaching or servicing the land leveler.
- 2† Keep hands, feet, hair and all clothing away from all moving parts and/or rotating parts.
- 3† Do not allow passengers on the land leveler or tractor.
- 4† Do not remove protective guards or shields† Ensure they are in place and properly attached.
- 5† Clear the area of all people, especially small children, prior to engaging the land leveler and/or the tractor.
- 6† Be extremely cautious while servicing or while near high pressure hydraulic systems. Ensure all components are fully sealed and in good working order prior to operating the equipment.
- 7† Ensure all reflectors, lights and the safety triangle are clean prior to transportation on public roads† Check with local authorities to ensure you are compliant with all lighting requirements.

## **Maintenance Safety**

In addition to reading and fully understanding this manual, you should:

- 1† Lower the land leveler, stop the tractor' s engine, set controls to neutral, engage the emergency brake, remove the tractor' s ignition key and wait for all moving parts to come to a full stop prior to adjusting, detaching or servicing the land leveler.
- 2† Keep hands, feet, hair and all clothing away from all moving parts.
- 3† Clear the area of all people, especially small children, prior to engaging the land leveler and/or the tractor.
- 4† Place safety stands or blocks underneath the frame prior to removing the tires or working underneath the land lever.

- 5† Be extremely cautious while servicing or while near high pressure hydraulic systems† Ensure all components are fully sealed and in good working order prior to operating the equipment. Wear appropriate safety gear to protect your eyes and hands† Use a piece of wood or cardboard as a shield when examining a hose or fitting for a leak.
- 6† Always relieve pressure prior to disconnecting or servicing hydraulics
- 7† Always use original parts when any need replacing
- 8† Do not in any way modify this equipment, its components or its intended use† Fabrication S.Houle inc. will not be held responsible should breakage or injury occur as a result of using any non-approved parts or accessories
- 9† Do not operate equipment that is defective or that has parts missing
- 10† Inspect nuts and bolts regularly and ensure they are tightly secure.

### **Hydraulic System Safety**

In addition to reading and fully understanding this manual, you should:

- 1† Always set the hydraulic controls to neutral prior to disassembling the hydraulic system.
- 2† Be extremely cautious while servicing or while near high pressure hydraulic systems† Ensure all components are fully sealed and in good working order prior to operating the equipment. Wear appropriate safety gear to protect your eyes and hands† Use a piece of wood or cardboard as a shield when examining a hose or fitting for a leak.

### **Transportation Safety**

In addition to reading and fully understanding this manual, you should:

- 1† Check with local authorities to ensure you are compliant with all machinery transportation safety requirements.



## **Storage Safety**

- 1⚡ Store the land leveler in an area well away from human activity.
- 2⚡ Store the land leveler in the lowered position.
- 3⚡ Do not allow children to play near the stored land leveler.

## **Tire Safety**

- 1⚡ Failure to follow appropriate directions while installing a tire on a wheel or rim may result in a blow-out, which could cause serious injury or death.
- 2⚡ Never attempt to install a tire unless you have the materials and equipment required and have appropriate experience to do so.
- 3⚡ See a well known tire repair facility or dealer for any repair or maintenance work required.





## Greasing

Locate the greasing decals (see illustration on right)

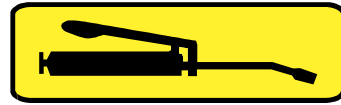

- 1† Use a manual grease gun
- 2† Clean the couplers and fittings with a clean cloth prior to lubricating
- 3† Replace and repair damaged or broken couplers
- 4† If couplers are difficult to lubricate, remove them so as to be able to clean them thoroughly, and replace them if necessary Also clean the lubricant passageway
- 5† Inject lubricant until the excess is expelled through the bearing or bushing areas.

## Types of Lubricants

### Grease

Use an SAE multi-purpose high temperature grease with extreme pressure (EP) performance† A lithium-based SAE multi-purpose grease is also acceptable.



# LAND LEVELER LN-16 FRAME KIT N0216-05E04

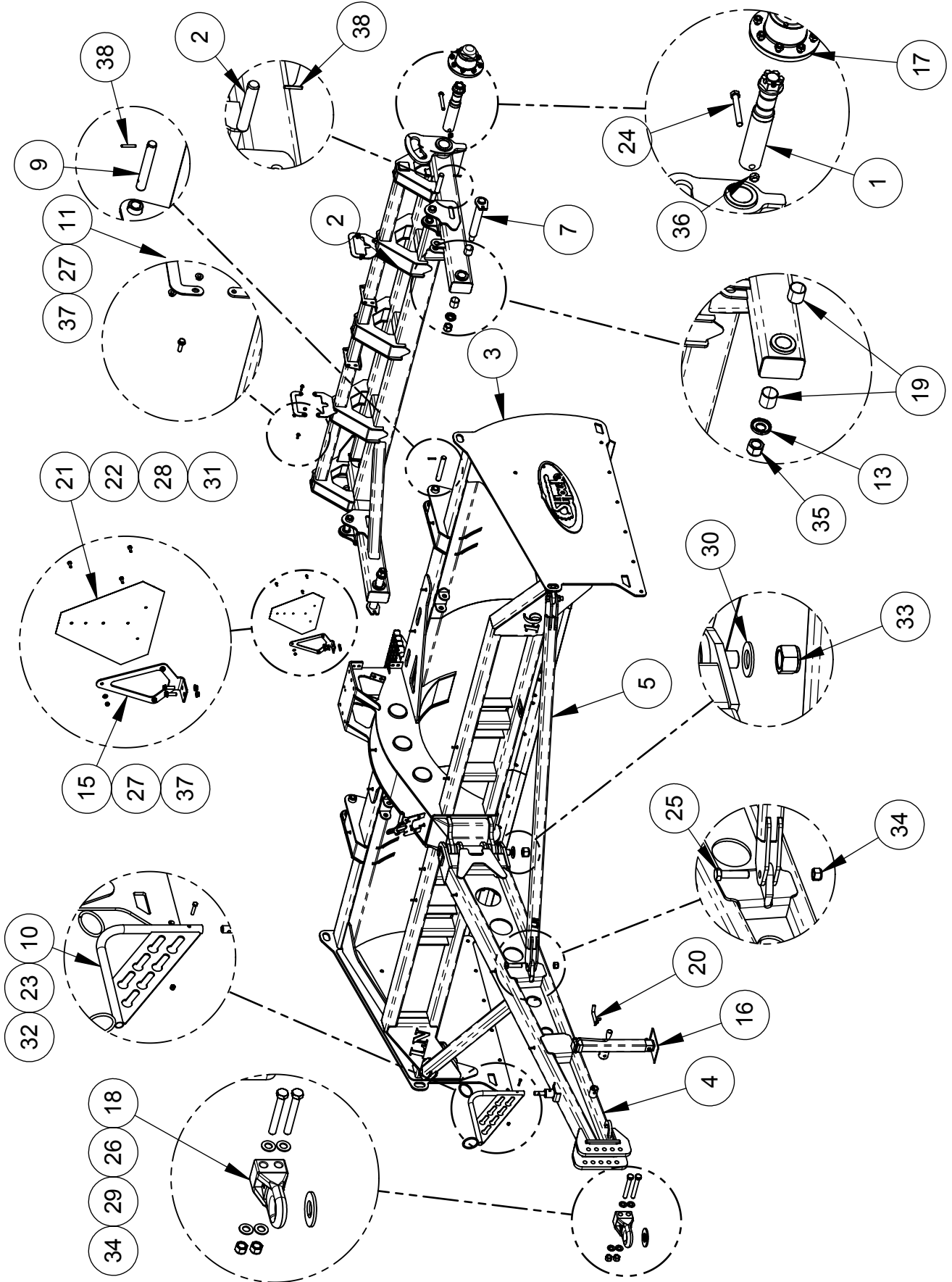



## ENS. CHASSIS NIVELEUSE LN-16 N0216-05E04

ITEM	NO	DESCRIPTION	QTY
1	N-01006	SPINDLE 12,000 LBS ASS'Y	2
2	N-01125	LN-16 SWING ARM	1
3	N-05195	LAND LEVELER LN-16 FRAME	1
4	N-05131	LAND LEVELER LN14/16/18 TONGUE	1
5	N-05034	REINFORCEMENT ARM LN-16	1
6	N-05034	REINFORCEMENT ARM LN-16	1
7	N-25003	PIN 2" X 14 1/4"	2
8	N-25010	PIN 2" X 19 1/2"	1
9	N-25051	PIN 1 1/2" X 8 5/8"	2
10	N-43014	SWIVEL HOSE SUPPORT	1
11	N-43016	REINFORCEMENT BAR LOCK DEVICE (LN & SLN)	2
12	UN-20037	QUICK HITCH CAT.4 WEAR PLATE	1
13	UN-28008-3	COMPRESSION WASHER 2 1/4" IDx 2 3/4"ODx 1/4" (1 5/16")	2
14	UN-25009-7	PIN 1 1/2" X 6 3/4" (1 HOLE)	2
15	UN-36001	SMV HOLDER	1
16	UN-43003	JACK 7000 LBS	1
17	01002-5	12,00 LBS HUB	2
18	20003	HITCH CAT.3 (PPI-301V3)	1
19	34016-3	PLAIN BEARING G300 2" ID. X 2" LG	4
20	35011-2	BENT PULL PIN 3/4" X 3 1/2"	1
21	36002	SLOW MOVING VEHICLE SIGN (SMV)	1
22	45AA004200012	HEX BOLT 1/4-20NC x 3/4" GR5	3
23	45AA006160200	HEX BOLT 3/8-16NC x 2" GR5	1
24	45AA012100508	HEX BOLT 3/4-10NC x 5 1/2" GR5	2
25	45AA100080400	HEX BOLT 1-8NC X 4" GR5	4
26	45AB100080708	HEX BOLT 1"-8NC X 7 1/2" GR8	2
27	45AE006160104	WHIZ-LOCK BOLT 3/8-16NC X 1 1/4"	6
28	46AB004	HARDENED FLAT WASHER 1/4"	3
29	46AB100	HARDENED FLAT WASHER 1"	4
30	46AB108	HARDENED FLAT WASHER 1 1/2"	1
31	47AB00420	NYLON LOCK NUT 1/4-20 NC	3
32	47AB00616	NYLON LOCK NUT 3/8"-16NC	1
33	47AB10806	NYLON NUT 1 1/2-6NC	1
34	47AB10008	NYLON LOCK NUT 1"-8NC	6
35	47AB10407	NYLON LOCK NUT 1 1/4"-7NC	2
36	47AC01210	STOVER LOCK NUT 3/4-10NC	2
37	47AE00616	FLANGE NUT 3/8-16NC	6
38	49AA050200	SPRING PIN 5/16"X2"	4



# LAND LEVELER LN-16 CUTTING EDGE KIT N0216-21E02

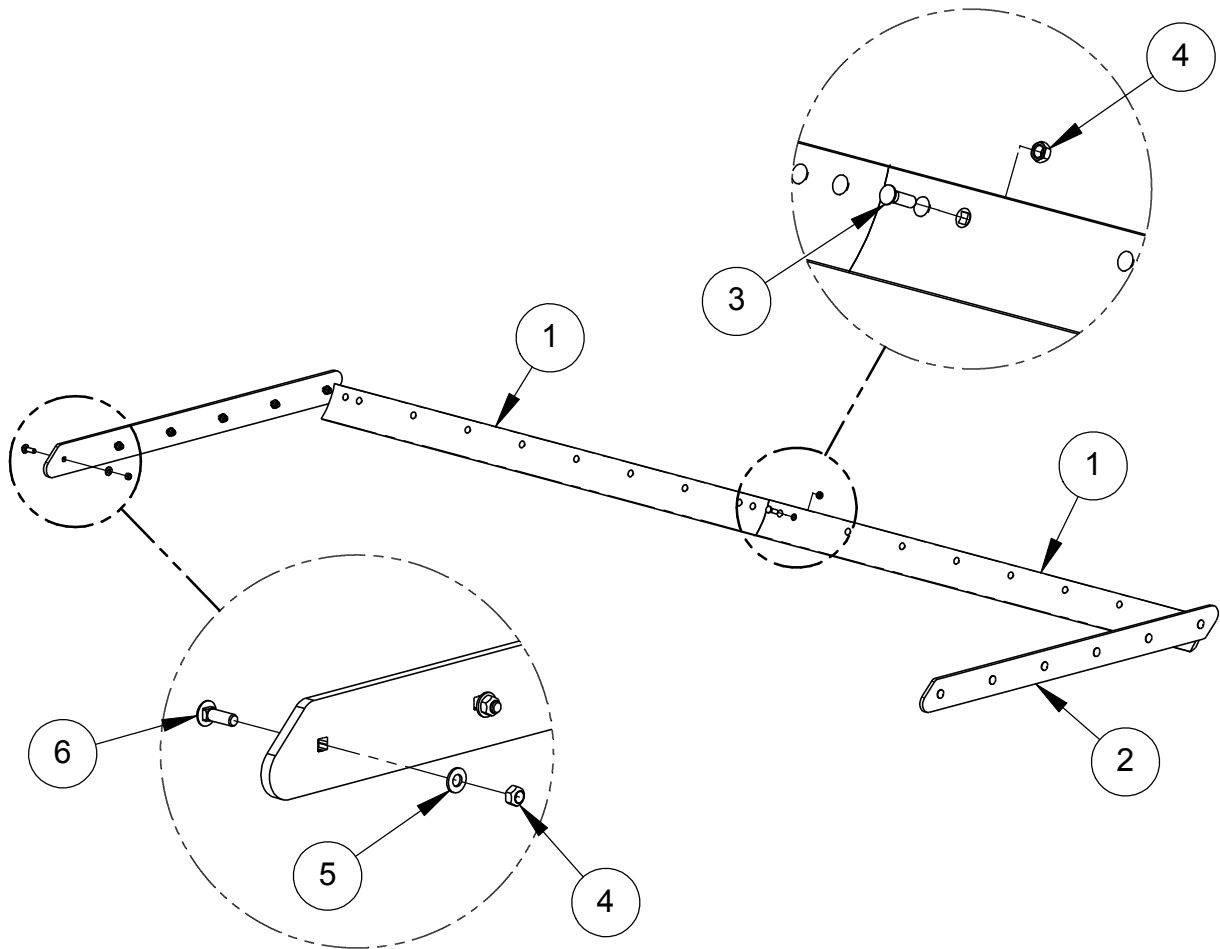

#	P. NUMBER	DESCRIPTION	QTY
1	21012-3	ROUND CUTTING EDGE 5/8" X 6" X 8' (5/8")	2
2	N-21008	SIDE PANEL CUTTING EDGE 5/8" X 5" X 65 3/8" (HOLE 5/8")	2
3	45CA010110200	SCAPER BOLT DOME H. 5/8-11 X 2" GR5	20
4	47AC01011	STOVER LOCK NUT 5/8-11NC	32
5	46AB010	HARDENED FLAT WASHER 5/8"	12
6	45CC010110200	CARRIAGE BOLT 5/8"-11NC X 2" GR5	12



# LN-16 SWING ARM HYD. KIT N0216-31E01

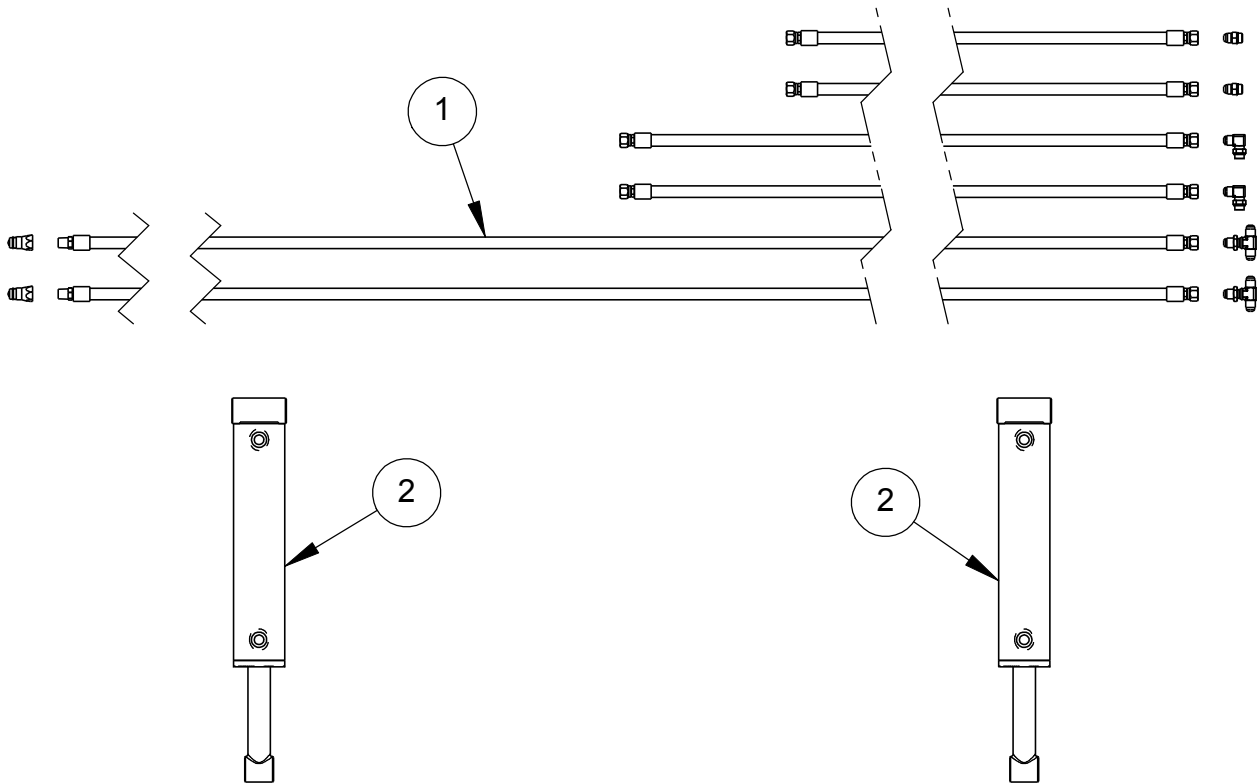

#	P. NUMBER	DESCRIPTION	QTE
1	N0216-29E01	HYDRAULIC HOSES KIT LN16 (SWING ARM)	1
2	30014	HYD. CYLINDER 3 1/2" X 14" (BUSHING)	2

## N0216-29E01

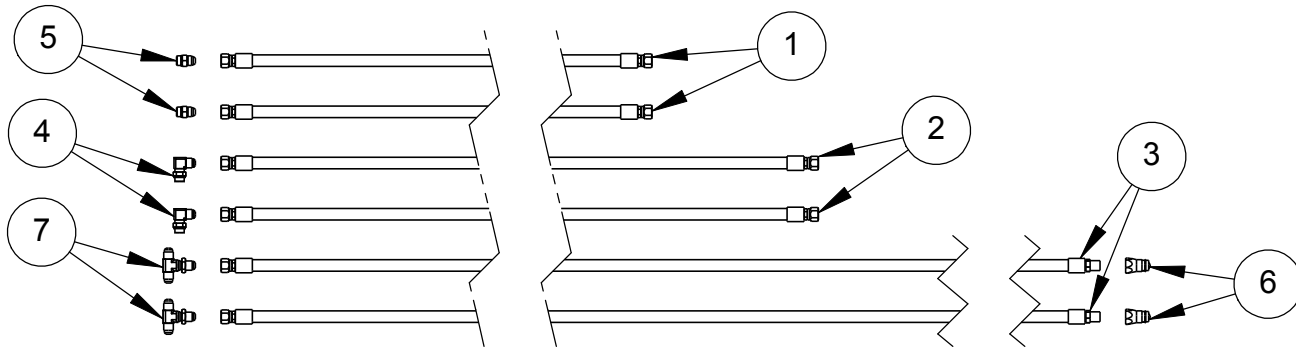

#	P. NUMBER	DESCRIPTION	QTY
1	UN-29009-089	HYD. HOSE 1/2" LP 1/2" JIC(F) x 1/2" JIC(F) X 89"	2
2	UN-29009-102	HYD. HOSE 1/2" LP 1/2" JIC(F) x 1/2" JIC(F) X 102"	2
3	UN-29008-228	HYD. HOSE 1/2" LP 1/2" JIC(F) x 1/2" NPT(M) X 228"	2
4	31013-16	ADAP. 1/2" ORB(M) / 1/2" JIC(M)(90)	2
5	31014-14	ADAP. 1/2" JIC(M) / 1/2" ORB(M)(STR)	2
6	31016	QUICK COUPLER MALE 1/2"NPT(F) (S71-4)	2
7	31021-3	BULK HEAD ADAP. 1/2" JIC(M) / 1/2" JIC(M) / 1/2" JIC(M)(TE)(LOCK NUT)	2



# LN COUNTERWEIGHT KIT (1200 PD) N02-05E02

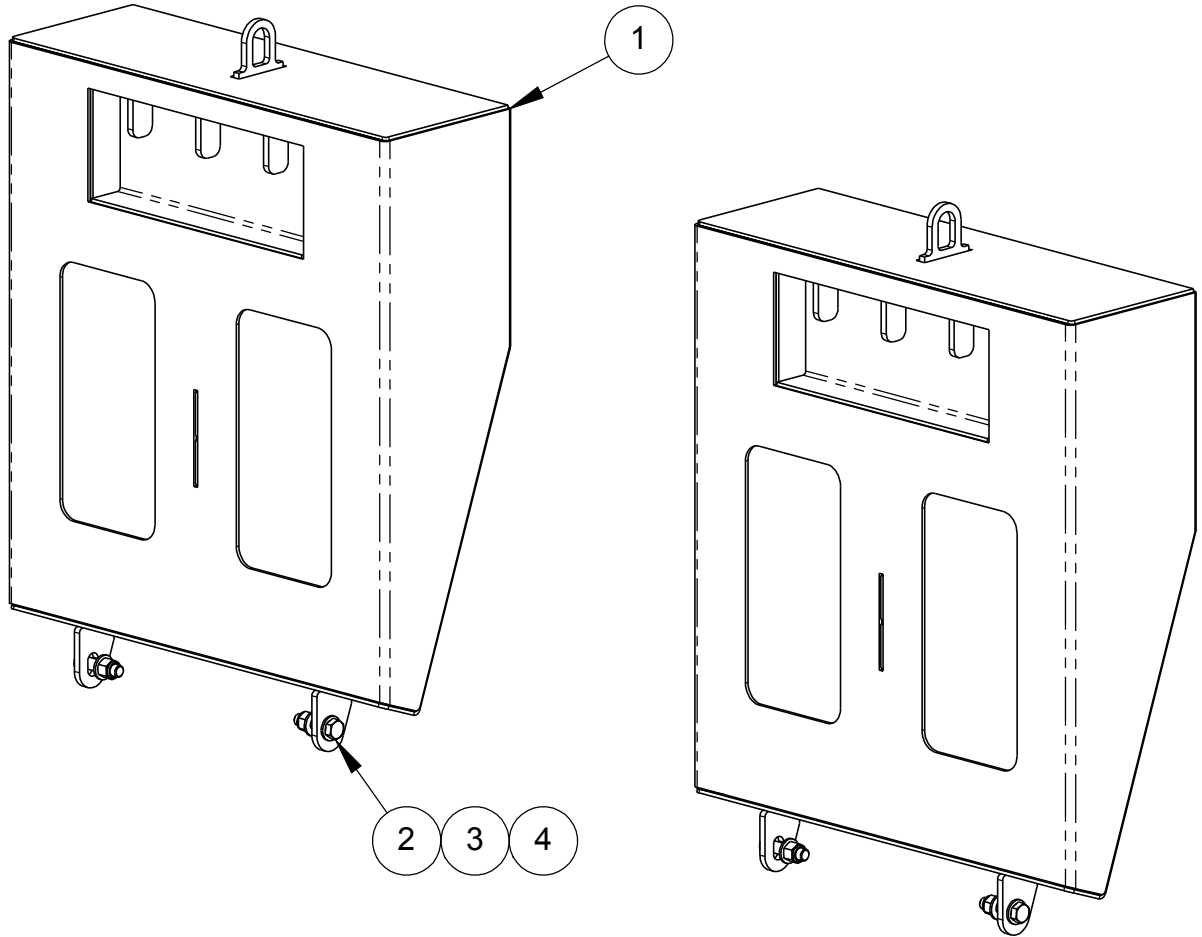

#	P. NUMBER	DESCRIPTION	QTY
1	N-05134	LN COUNTERWEIGHT (600 PD)	2
2	45AA010110208	HEX BOLT 5/8-11NC x 2 1/2" GR5	4
3	46AB010	HARDENED FLAT WASHER 5/8"	8
4	47AB01011	NYLON NUT 5/8-11NC	4



# SECURITY LIGHT KIT N-32E01

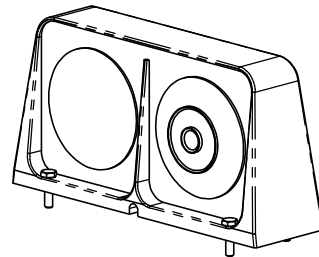
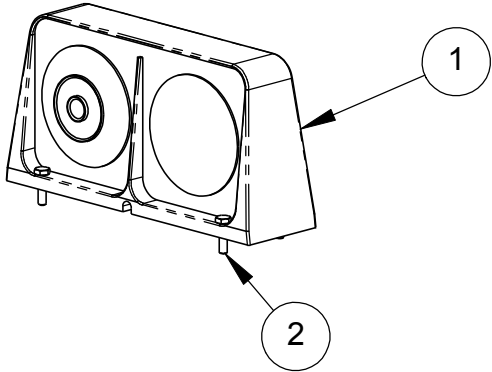

#	P. NUMBER	DESCRIPTION	QTE
1	32002	SECURITY LIGHT KIT	1
2	45AA004200100	HEX BOLT 1/4-20NC x 1" GR5	8



# GPS POST KIT (SLN) N-36E02

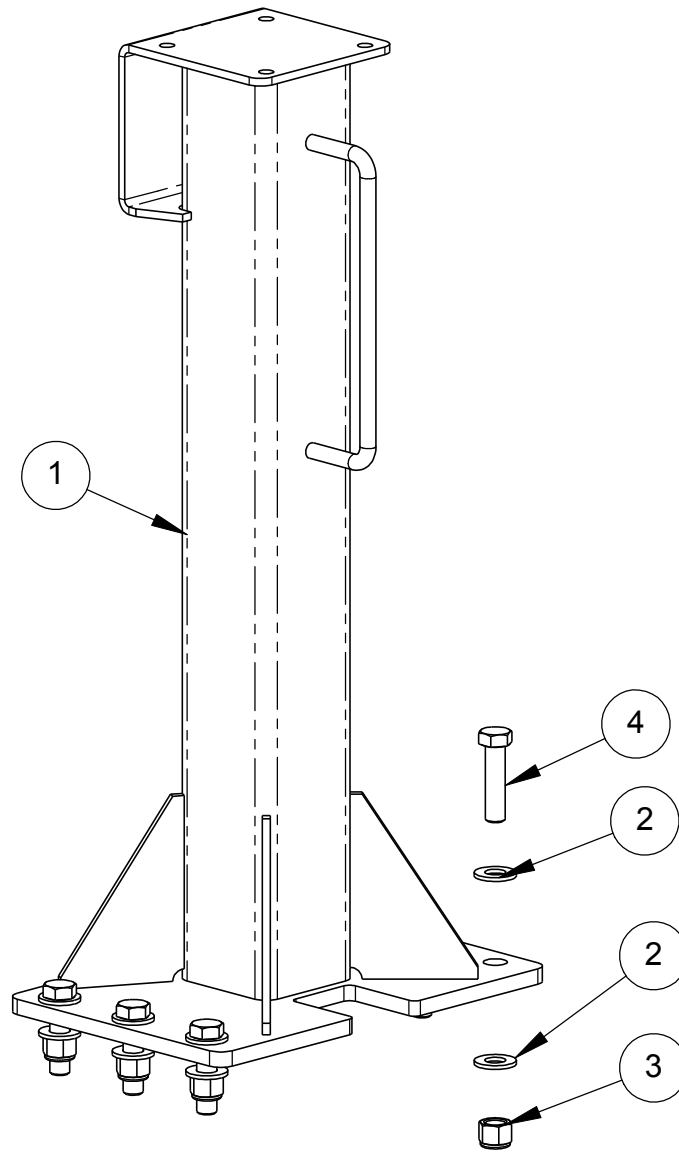

#	P. NUMBER	DESCRIPTION	QTY
1	N-05025	GPS POST	1
2	46AB010	HARDENED FLAT WASHER 5/8"	12
3	47AB01011	NYLON NUT 5/8-11NC	6
4	45AA010110208	HEX BOLT 5/8-11NC x 2 1/2" GR5	6





# LASER POST KIT N-36E03

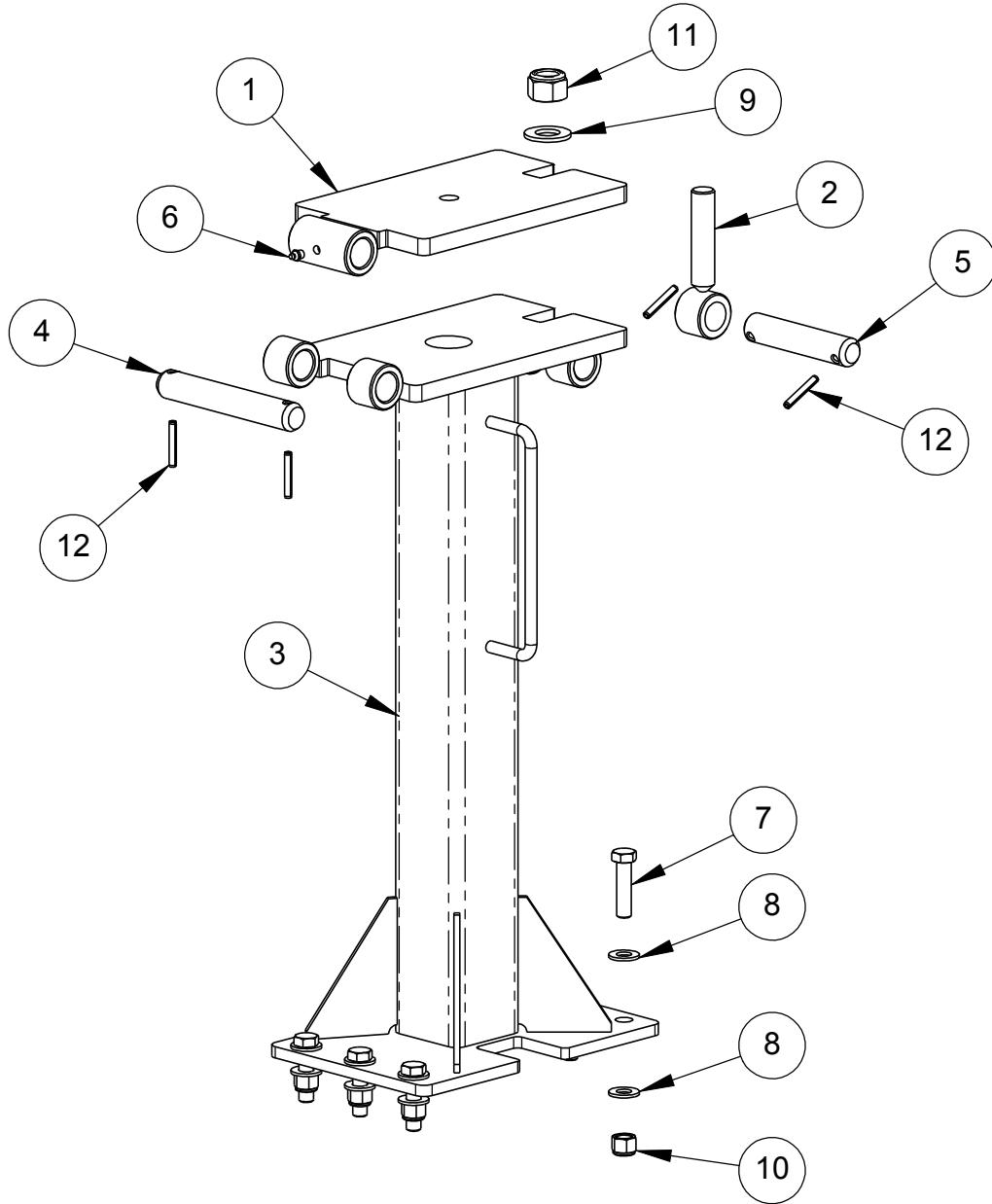

#	P. NUMBER	DESCRIPTION	QTY
1	N-36002	FLEXIBLE LASER SUPPORT	1
2	N-36004	LASER LOCK PIN	1
3	N-05043	LASER POST	1
4	N-36003	PIN 1 1/4" X 8" LG (2 HOLES)	1
5	UN-25001-5	PIN 1 1/4" X 6 1/8" (2 HOLES) (PLATED)	1
6	35012	STRAIGHT GREASE FITTING 1/8 NPT	1
7	45AA010110208	HEX BOLT 5/8-11NC x 2 1/2" GR5	6
8	46AB010	HARDENED FLAT WASHER 5/8"	12
9	46AB100	HARDENED FLAT WASHER 1"	1
10	47AB01011	NYLON NUT 5/8-11NC	6
11	47AB10008	NYLON NUT 1-08NC	1
12	49AA050200	SPRING PIN 5/16" X 2"	4



# SCARIFIER TEETH ASS LN-16 N0216-21E05

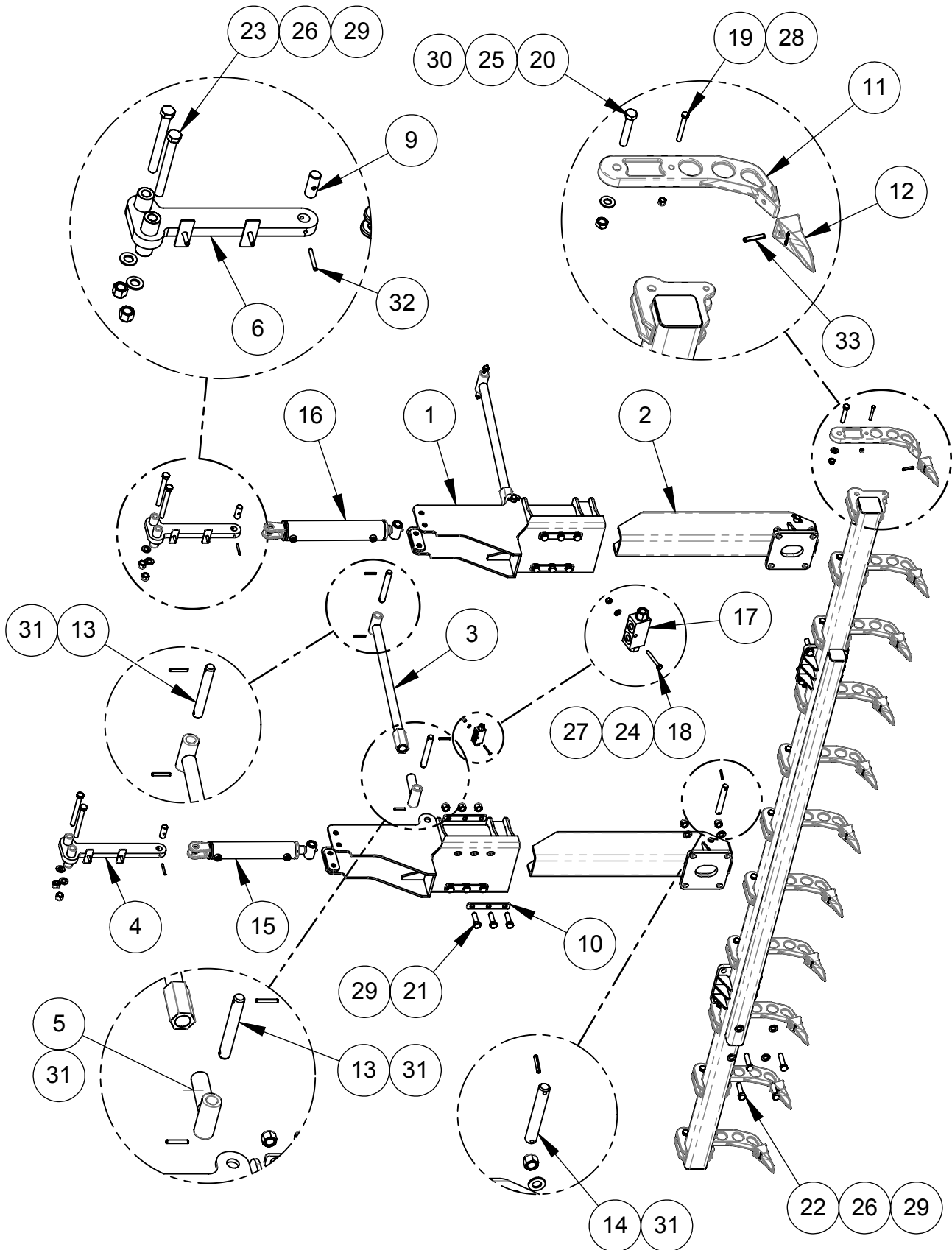



# SCARIFIER TEETH ASS LN-16 N0216-21E05

#	P. NUMBER	DESCRIPTION	QTY
1	N-05156	SCARIFIER POST (LN)	2
2	N-05157	SCARIFIER SLIDING POST	2
3	N-05054	TIE BAR	2
4	N-05028	HYDR. CYLINDER SUPPORT	1
5	N-05031	TIE ROD	2
6	N-05077	HYDR. CYLINDER SUPPORT	1
7	N-21041	SCARIFIER TEETH SUPPORT LN-16 / SLN-16	1
8	N0218-29E03	HYDRAULIC HOSES KIT LN-18 (SCARIFIER TEETH)	1
9	N-25014	PIN 1" X 2 1/2" LG	2
10	N-28002-2	3/4" TRIPLE FALT WASHER	8
11	UN-21001	SCARIFIER TIP HOLDER	11
12	UN-21002	SCARIFIER TIP	11
13	UN-25001-11	PIN 1" X 7 3/8" (2 HOLES)	4
14	UN-25001-36	PIN 1" X 6 3/4" (2 HOLES)	2
15	UN-30561	IN LINE HYDR. CYLINDER 2 1/2" X 11" , CL100 X BU100	1
16	UN-30581	IN LINE HYDR. CYLINDER 3" X 16" , CL100 X BU100	1
17	31069	DOUBLE PILOT OPERATED CHECK VALVE (3/8" ORB)	1
18	45AA004200200	HEX BOLT 1/4-20NC x 2" GR5	1
19	45AA006160300	HEX BOLT 3/8-16NC X 3" GR5	11
20	45AA010110308	HEX BOLT 5/8-11NC X 3 1/2" GR5	11
21	45AA012100208	HEX BOLT 3/4-10NC X 2 1/2" GR5	12
22	45AA012100300	HEX BOLT 3/4-10NC X 3" GR5	8
23	45AA012100700	HEX BOLT 3/4-10NC x 7" GR5	4
24	46AB004	HARDENED FLAT WASHER 1/4"	1
25	46AB010	HARDENED FLAT WASHER 5/8	11
26	46AB012	HARDENED FLAT WASHER 3/4"	20
27	47AB00420	NYLON NUT 1/4-20NC	1
28	47AB00616	NYLON LOCK NUT 3/8"-16NC	11
29	47AB01210	NYLON NUT 3/4-10NC	24
30	47AC01011	STOVER LOCK NUT 5/8-11NC	11
31	49AA050200	SPRING PIN 5/16" X 2"	12
32	49AA050208	SPRING PIN 5/16" x 2 1/2"	2
33	49AA060200	SPRING PIN 3/8" x 2"	11

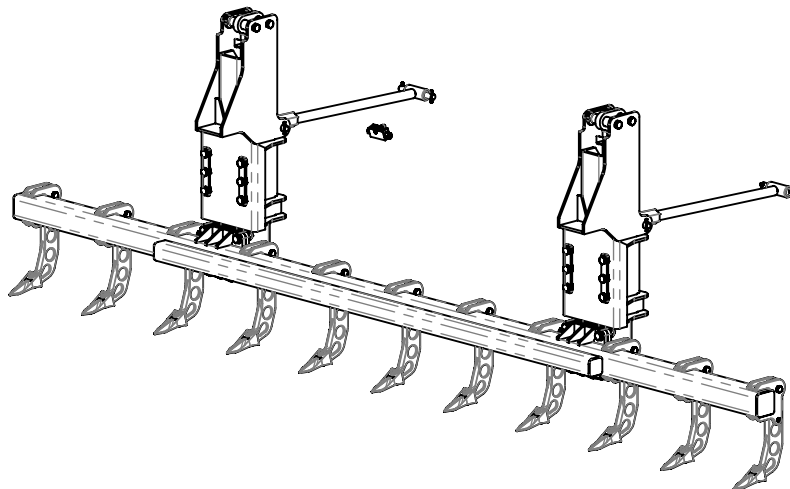



# HYDRAULIC HOSES KIT LN-16 (SCARIFIER TEETH) N0216-29E03

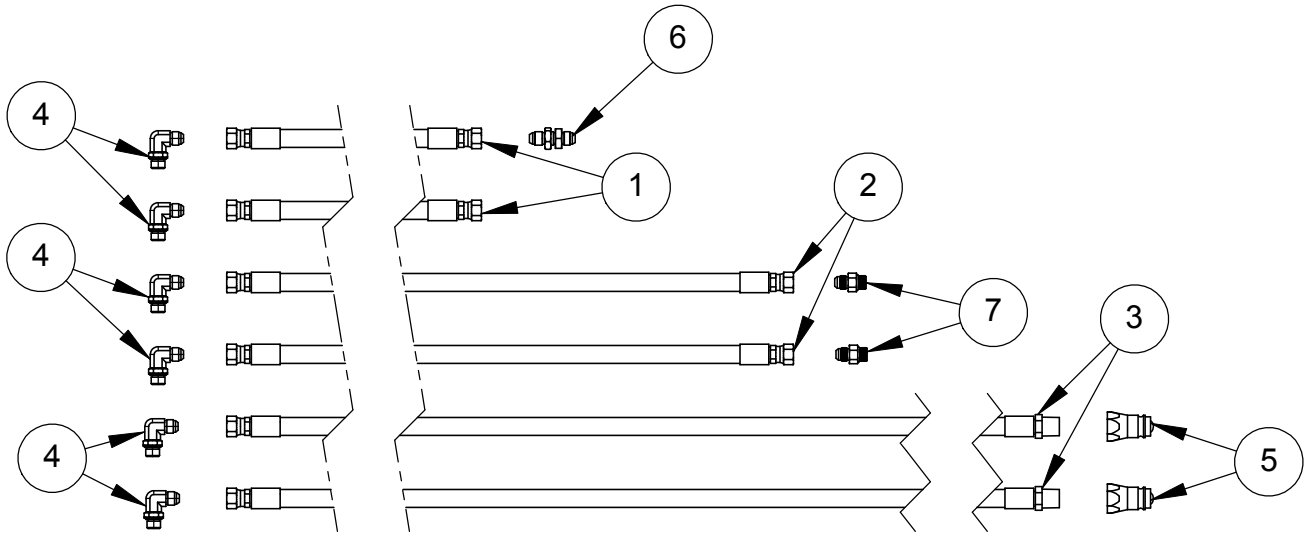

#	P. NUMBER	DESCRIPTION	QTY
1	UN-29001-075	HYD. HOSE 3/8" LP 3/8" JIC(F) x 3/8" JIC(F) X 75"	2
2	UN-29001-088	HYD. HOSE 3/8" LP 3/8" JIC(F) x 3/8" JIC(F) X 88"	2
3	UN-29002-180	HYD. HOSE 3/8" LP 3/8" JIC(F) x 1/2" NPT(M) X 180"	2
4	31013-5	ADAP. 3/8" ORB(M) / 3/8" JIC(M)(90)	6
5	31016	QUICK COUPLER MALE 1/2"NPT(F) (S71-4)	2
6	31034-2	ADAP. BULK HEAD 3/8" JIC(M) / 3/8" JIC(M)(STR)(WITH NUT)	1
7	31014-5		2



**IN LINE HYDR. CYLINDER 2 1/2" X 11" , CL100 X BU100  
UN-30561**

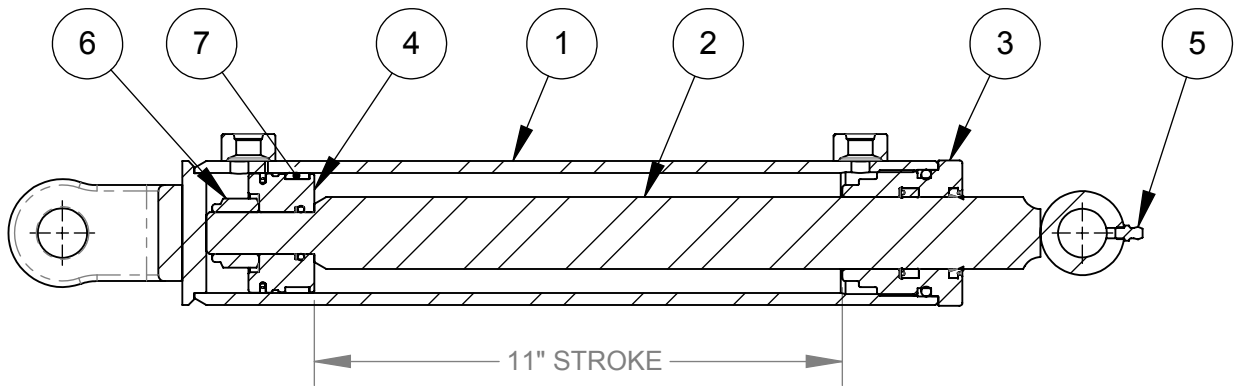
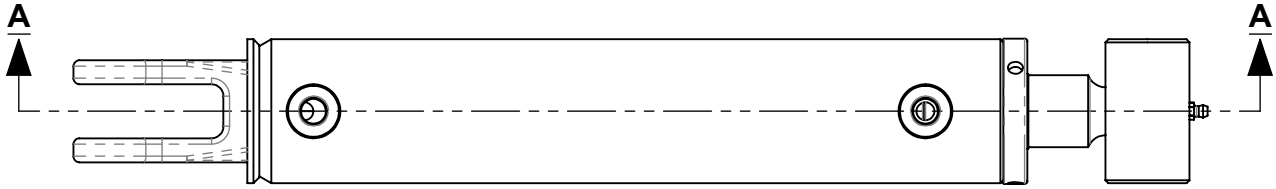

#	P. NUMBER	DESCRIPTION	Ferm é/QT Y
1	UN-30014-22	IN LINE 2 1/2" TUBING, CL 100	1
2	UN-30021-18	CYLINDER ROD 1 1/2", BU100	1
3	UN-30024	TETE 2 1/2" SÉRIE TIGE 1 1/2"	1
4	UN-30026-2	PISTON 2 1/2" IN LINE	1
5	35012-5	GREASE FITTING 1/4-28 NF	1
6	47AB01414	NYLON NUT 7/8-14NF	1
7	UN-30E05	SEAL KIT 11 2 1/2" IN LINE (1 1/2 ROD)	1



**IN LINE HYDR. CYLINDER 3" X 16" , CL100 X BU100  
UN-30581**

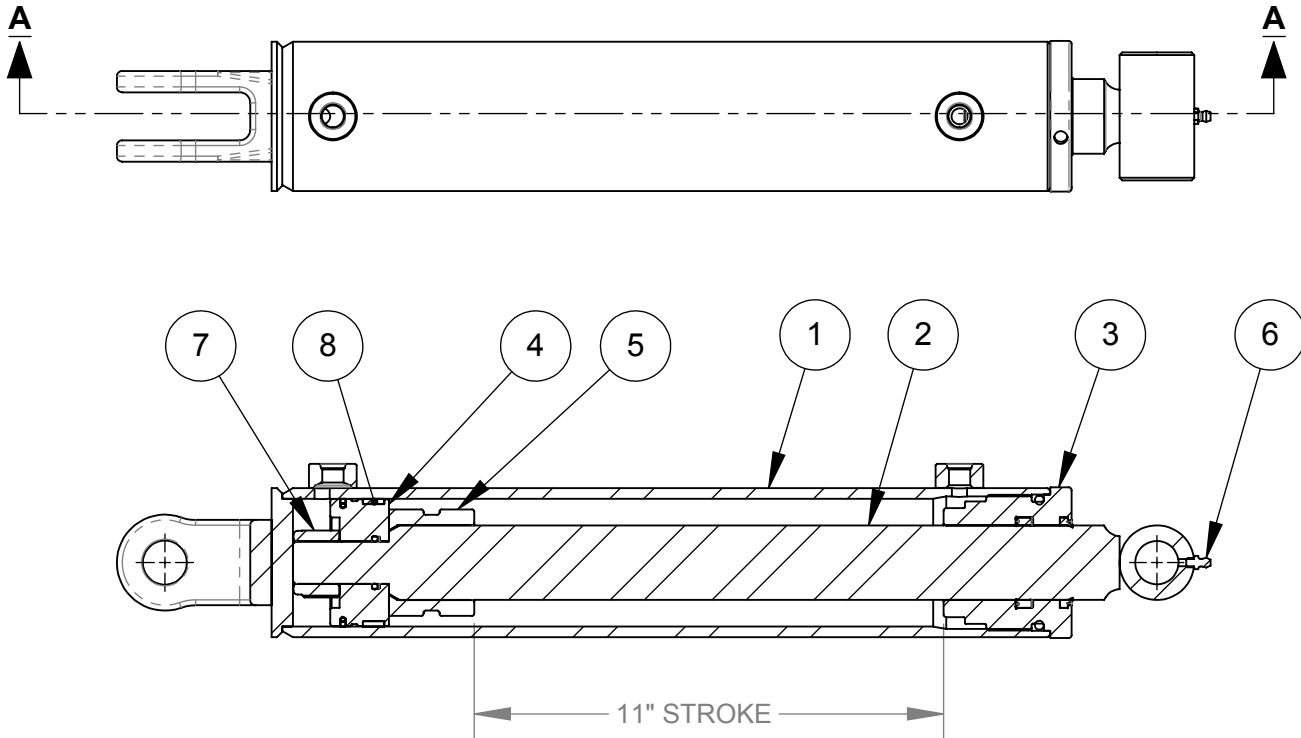

#	P. NUMBER	DESCRIPTION	QTY
1	UN-30014-39	IN LINE 3" TUBING, CL100	1
2	UN-30020-54	ROD 1 3/4" , BU100	1
3	UN-30023-4	CYLINDER HEAD 3" STD (1 3/4" ROD)	1
4	UN-30026-4	PISTON 3" IN LINE	1
5	UN-30043-4	SPACER 2" ROD 1 3/4"	1
6	35012-5	GREASE FITTING 1/4-28 NF	1
7	47AB10014	NYLON LOCK NUT 1"-14NF	1
8	UN-30E14	SEAL KIT 3" IN LINE (1 3/4" ROD)	1



**RIGHT TILT TANDEM KIT (LN)  
N02-01E01**

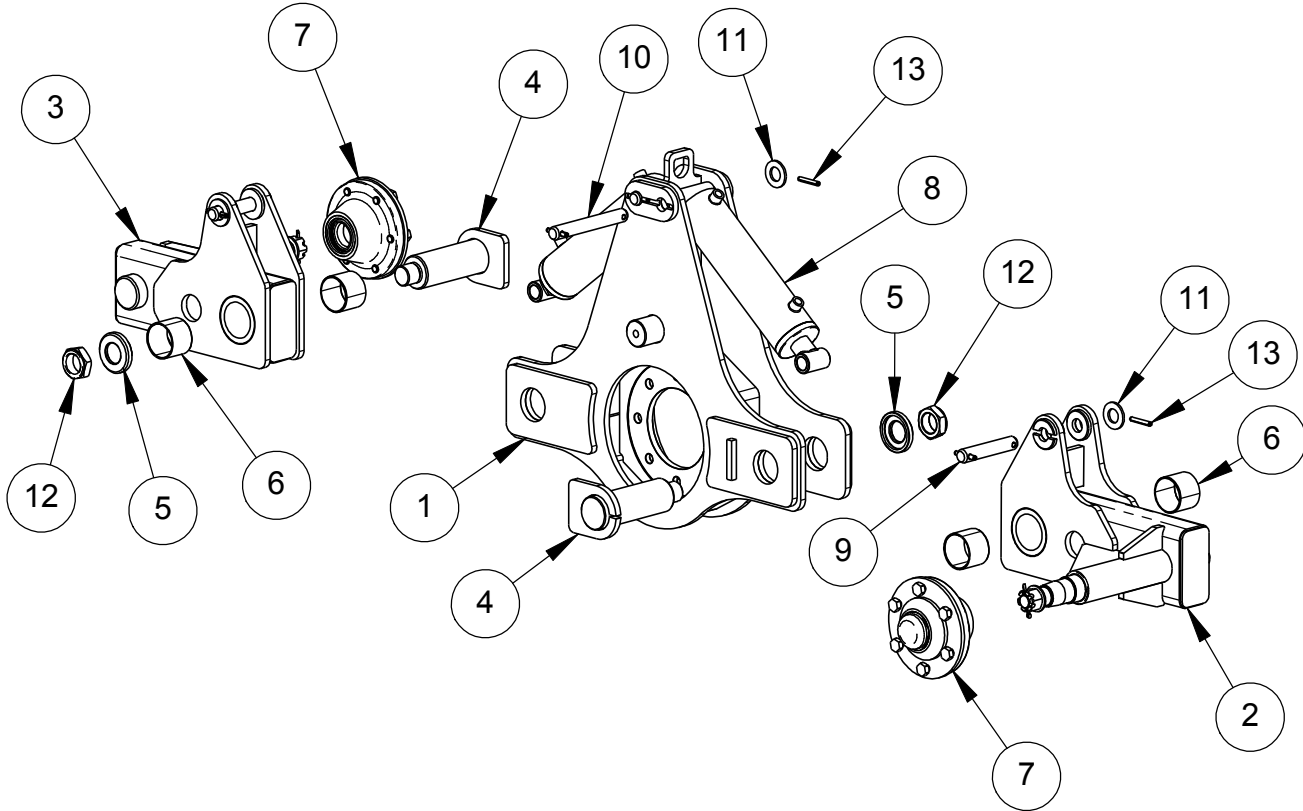

#	P. NUMBER	DESCRIPTION	QTY
1	N-01003	RIGHT TILT TANDEM (LN)	1
2	N-01004	RIGHT TILT TANDEM (LN)	1
3	N-01005	RIGHT TILT TANDEM (LN)	1
4	N-25004	PIN 2 1/2" X 6 5/16" LG	2
5	UN-28008-4	COMPRESSION WASHER 2 1/2"ID X 3" OD X 1/4" (1 9/16")	2
6	34016	BUSHING G300 2 1/2"ID X 2" LG	4
7	01002	5000 LBS HUB	2
8	30003	HYD. CYLINDER 3" X 8" (BUSHING)	2
9	UN-25001-10	PIN 1" X 5 1/2" (2 HOLES)	2
10	UN-25001-11	PIN 1" X 7 3/8" (2 HOLES)	2
11	46AB100	HARDENED FLAT WASHER 1"	4
12	47AG10806	THIN NYLON LOCK NUT 1 1/2-6NC	2
13	49AA050200	SPRING PIN 5/16" X 2"	8



# RIGHT FIXED TANDEM KIT (LN) N02-01E02

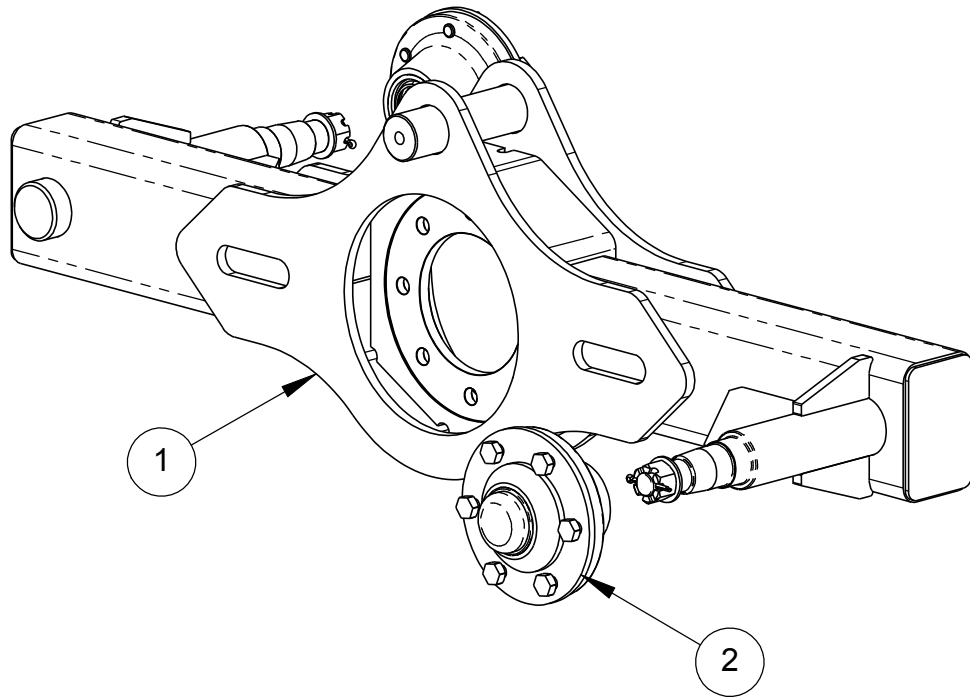

#	P. NUMBER	DESCRIPTION	QTY
1	N-01002	RIGHT FIXES TANDEM (LN)	1
2	01002	5000 LBS HUB	2





# LEFT AJUSTABLE TANDEM KIT (LN) N02-01E03

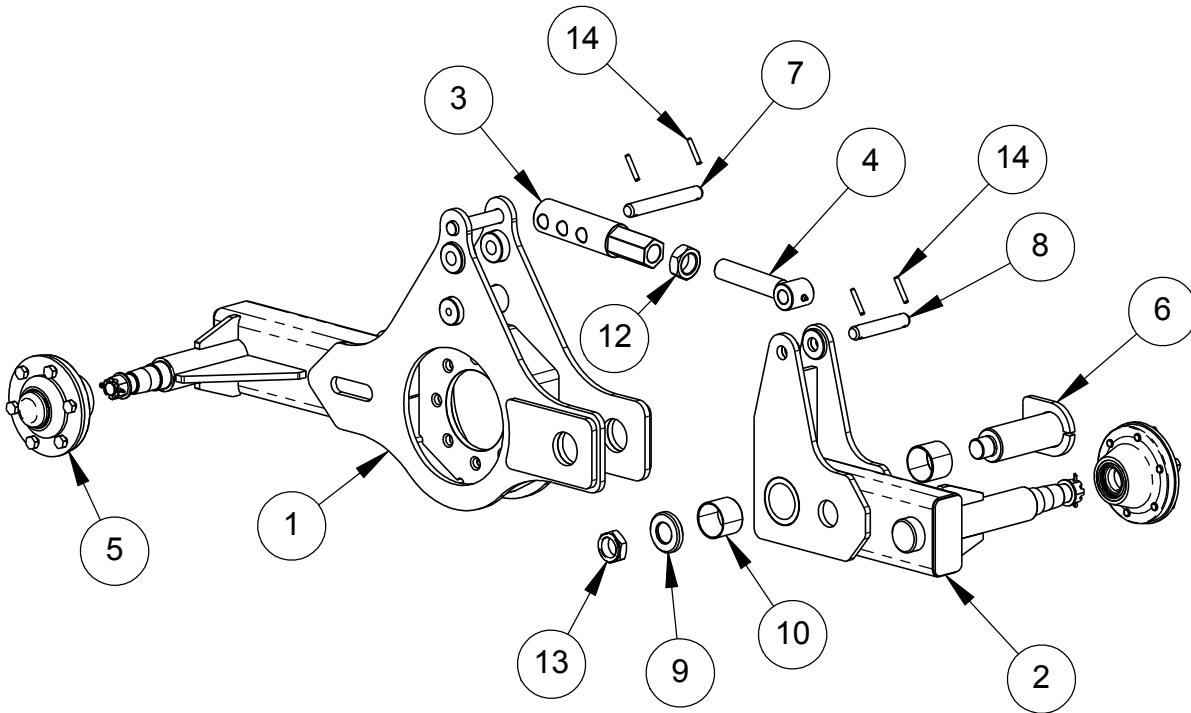

#	P. NUMBER	DESCRIPTION	QTY
1	N-01007		1
2	N-01009	LEFT AJUSTABLE TANDEM (LN)	1
3	N-01010	AJUSTABLE ARM	1
4	N-01011	AJUSTABLE ARM (ROD)	1
5	01002	5000 LBS HUB	2
6	N-25004	PIN 1/2" X 6 5/16" LG	1
7	UN-25001-11	PIN 1" X 7 3/8" (2 HOLES)	1
8	UN-25001-10	PIN 1" X 5 1/2" (2 HOLES)	1
9	UN-28008-4	COMPRESSION WASHER 2 1/2"ID X 3" OD X 1/4" (1 9/16")	1
10	34016	BUSHING G300 2 1/2"ID X 2" LG	2
11	35012	STRAIGHT GREASE FITTING 1/8 NPT	1
12	47AF10806	HEX JAM NUT 1 1/2-6NC	1
13	47AG10806	THIN NYLON LOCK NUT 1 1/2-6NC	1
14	49AA050200	SPRING PIN 5/16" X 2"	4



# RIGHT AJUSTABLE TANDEM KIT (LN) N02-01E04

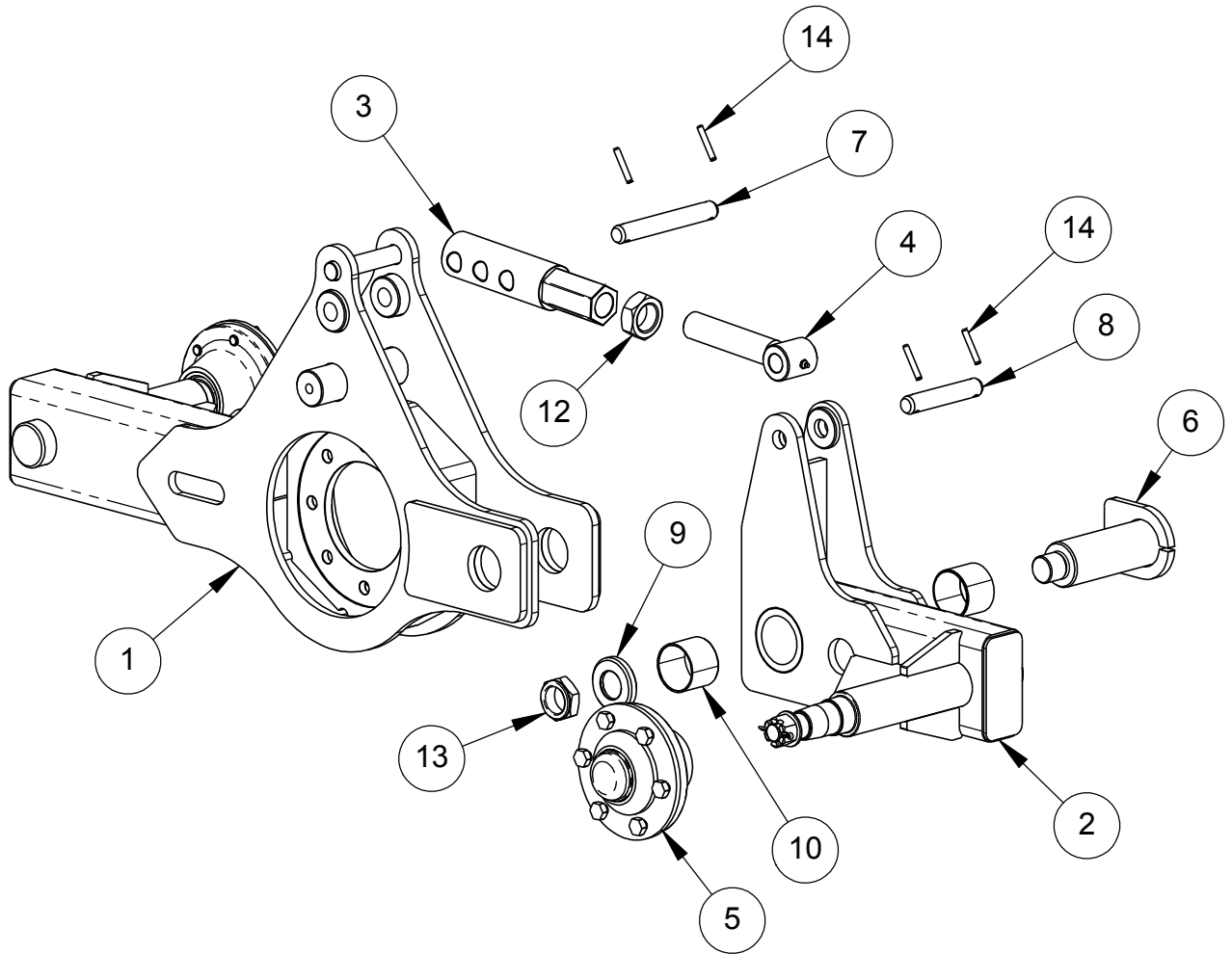

#	P. NUMBER	DESCRIPTION	QTY
1	N-01033	RIGHT AJUSTABLE TANDEM (LN)	1
2	N-01034	RIGHT AJUSTABLE TANDEM (LN)	1
3	N-01010	AJUSTABLE ARM	1
4	N-01011	AJUSTABLE ARM (ROD)	1
5	01002	5000 LBS HUB	2
6	N-25004	PIN 2 1/2" X 6 5/16" LG	1
7	UN-25001-11	PIN 1" X 7 3/8" (2 HOLES)	1
8	UN-25001-10	PIN 1" X 5 1/2" (2 HOLES)	1
9	UN-28008-4	COMPRESSION WASHER 2 1/2"ID X 3" OD X 1/4" (1 9/16")	1
10	34016	BUSHING G300 2 1/2"ID X 2" LG	2
11	35012	STRAIGHT GREASE FITTING 1/8 NPT	1
12	47AF10806	HEX JAM NUT 1 1/2-6NC	1
13	47AG10806	THIN NYLON LOCK NUT 1 1/2-6NC	1
14	49AA050200	SPRING PIN 5/16" X 2"	4



# LEFT TILT TANDEM KIT (LN) N02-01E05

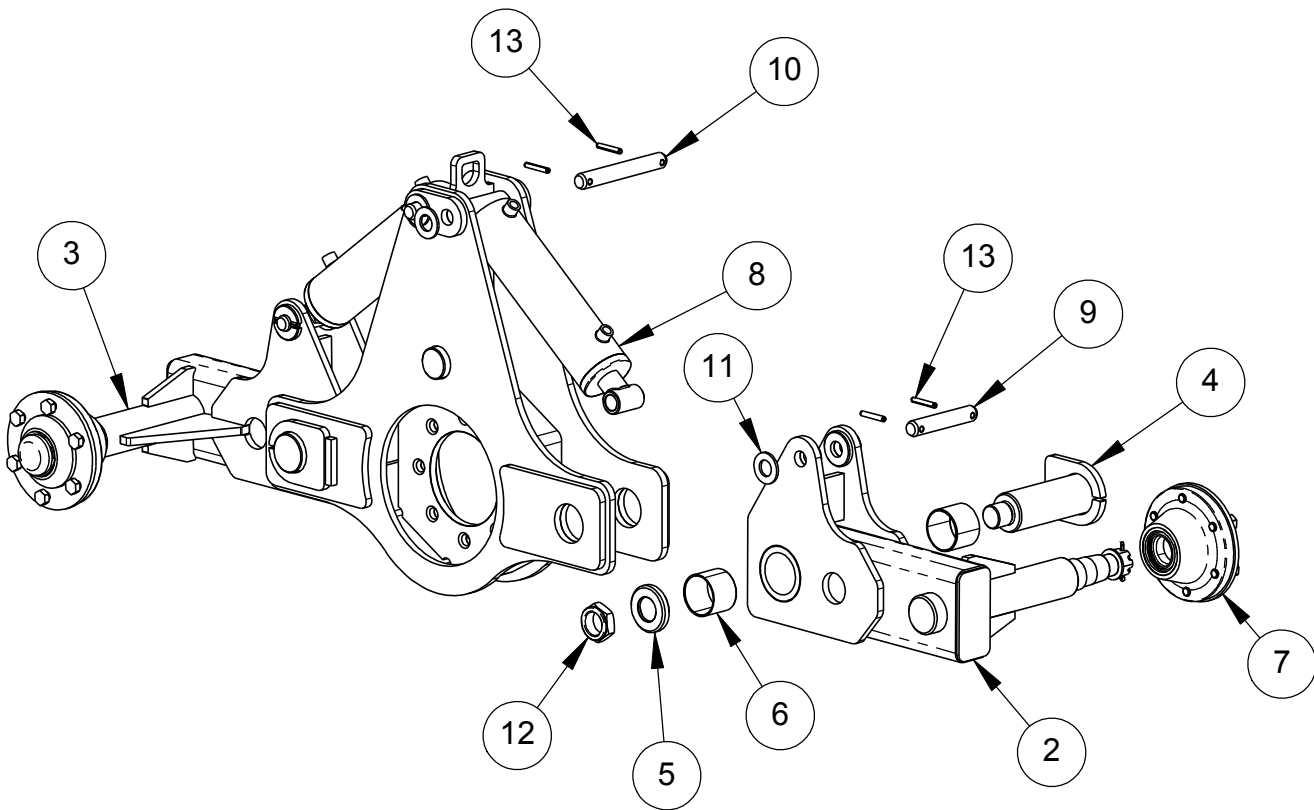

#	P. NUMBER	DESCRIPTION	QTY
1	N-01028	LEFT TILT TANDEM (LN)	1
2	N-01029	LEFT TILT TANDEM (LN)	1
3	N-01030	LEFT TILT TANDEM (LN)	1
4	N-25004	PIN 2 1/2" X 6 5/16" LG	2
5	UN-28008-4	COMPRESSION WASHER 2 1/2"ID X 3" OD X 1/4" (1 9/16")	2
6	34016	BUSHING G300 2 1/2"ID X 2" LG	4
7	01002	5000 LBS HUB	2
8	30003	HYD. CYLINDER 3" X 8" (BUSHING)	2
9	UN-25001-10	PIN 1" X 5 1/2" (2 HOLES)	2
10	UN-25001-11	PIN 1" X 7 3/8" (2 HOLES)	2
11	46AB100	HARDENED FLAT WASHER 1"	4
12	47AG10806	THIN NYLON LOCK NUT 1 1/2-6NC	2
13	49AA050200	SPRING PIN 5/16" X 2"	8



# HYDRAULIC HOSES KIT LN-16 (TANDEM) N0216-29E02

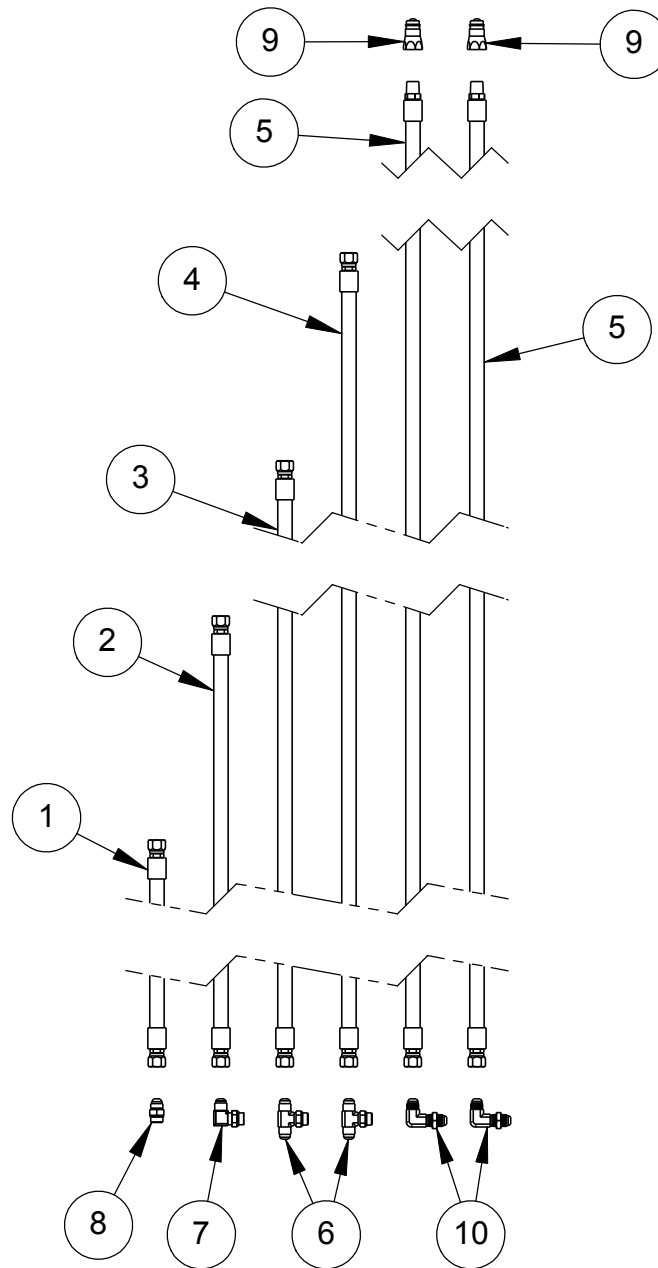

#	P. NUMBER	DESCRIPTION	QTY
1	UN-29009-018	HYD. HOSE 1/2" LP 1/2" JIC(F) x 1/2" JIC(F) X 18"	1
2	UN-29009-032	HYD. HOSE 1/2" LP 1/2" JIC(F) x 1/2" JIC(F) X 32"	1
3	UN-29009-125	HYD. HOSE 1/2" LP 1/2" JIC(F) x 1/2" JIC(F) X 125"	1
4	UN-29009-138	HYD. HOSE 1/2" LP 1/2" JIC(F) x 1/2" JIC(F) X 138"	1
5	UN-29008-232	HYD. HOSE 1/2" LP 1/2" JIC(F) x 1/2" NPT(M) X 232"	2
6	31002-5	ADAP. 1/2" JIC (M) / 1/2" ORB(M) / 1/2" JIC(M)(TEE)	2
7	31013-16	ADAP. 1/2" ORB(M) / 1/2" JIC(M)(90)	1
8	31014-14	ADAP. 1/2" JIC(M) / 1/2" ORB(M)(STR)	1
9	31016	QUICK COUPLER MALE 1/2"NPT(F) (S71-4)	2
10	31041-2	BULK HEAD ADAPT. 1/2" JIC(M) X 1/2" JIC(M) (90) (LOCK NUT)	2



**5000 LBS HUB  
01002**

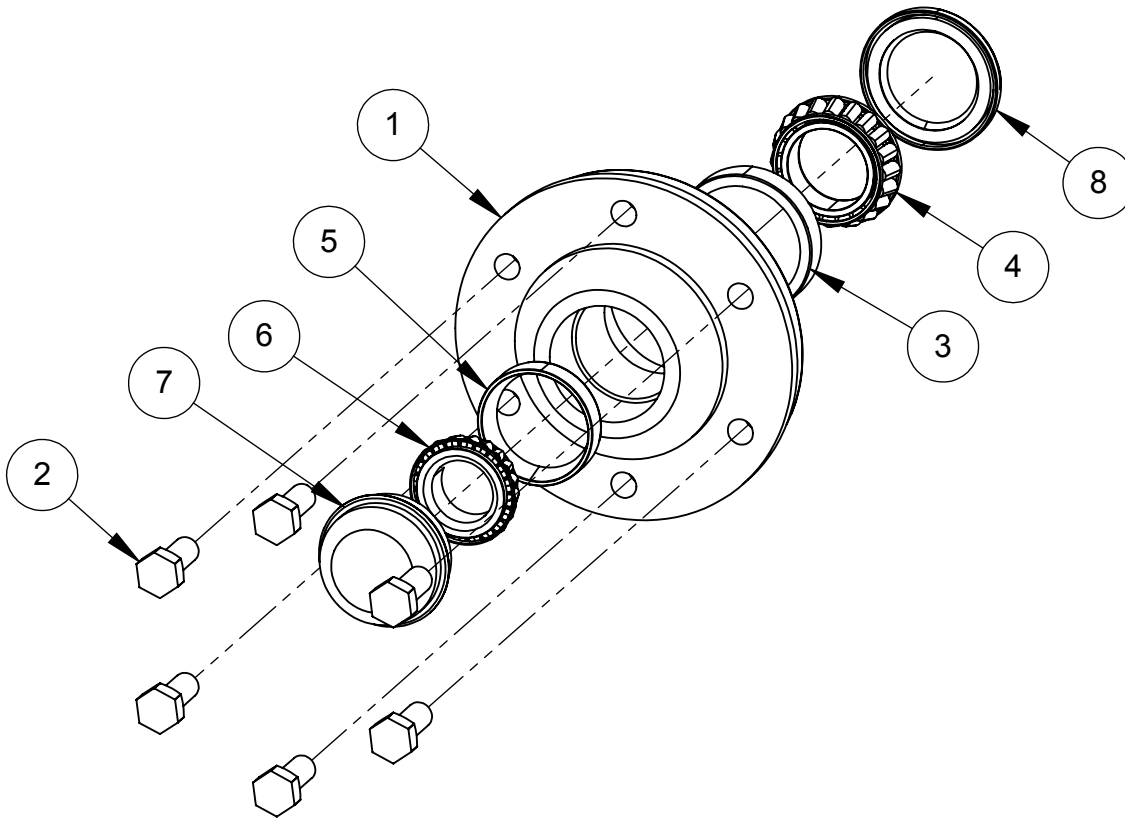

#	P. NUMBER	DESCRIPTION	QTY
1	01004	5000 LBS HUB	1
2	01009	WHEEL BOLT 9/16-18 NF x 1 3/4"	6
3	34009-2	BEARING CUP 3.063" OD	1
4	34008-2	BEARING CONE 1.780 ID	1
5	34009-3	BEARING CUP 2.563" OD	1
6	34008-3	BEARING CONE 1.375 ID	1
7	01006	DUST CAP	1
8	34010-2	OIL SEAL	1



**12,00 LBS HUB**  
**01002-5**

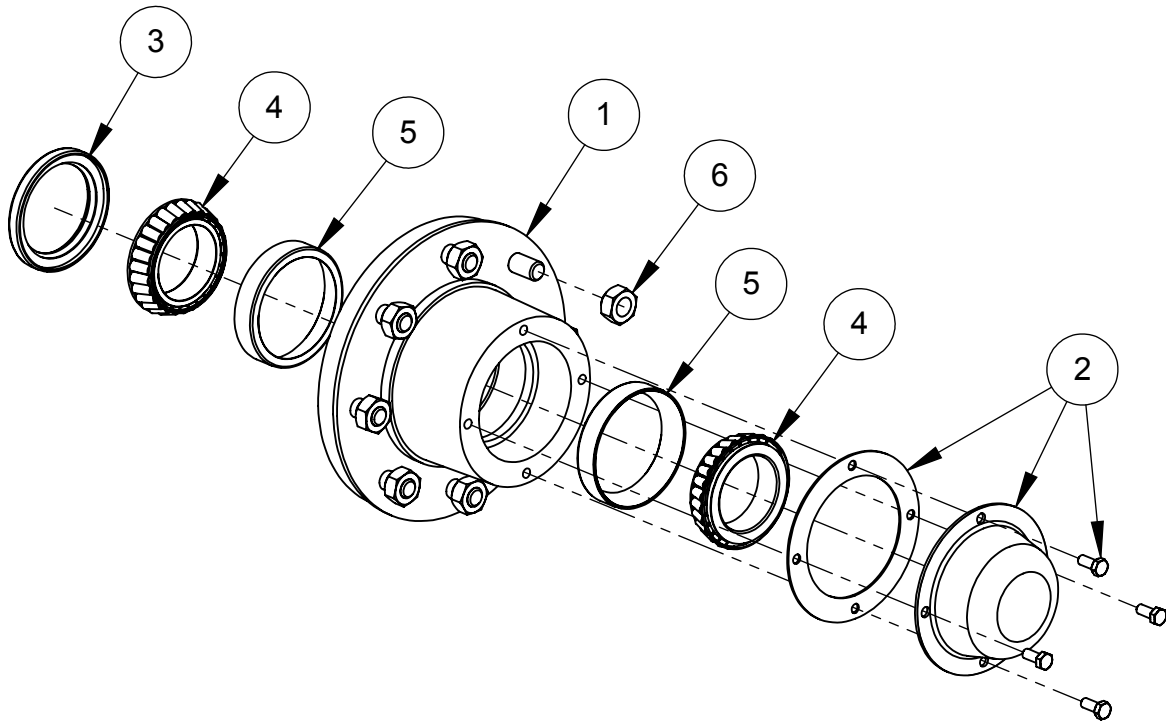

#	P. NUMBER	DESCRIPTION	QTY
1	01004-5	HUB BODY 12000 LBS	1
2	01006-5	12000 LBS HUB DUST CAP	1
3	01010-2	DUST SEAL 2.75 ID X 3.75 OD (12000 LBS HUB)	1
4	34008-6	TAPER BEARING 2.470" ID.	2
5	34009-6	CONE CUP 3.9375" OD	2
6	01007-2	5/8" HUB NUT	8



**AGRICULTURAL TIRE KIT.  
N02-03E01**

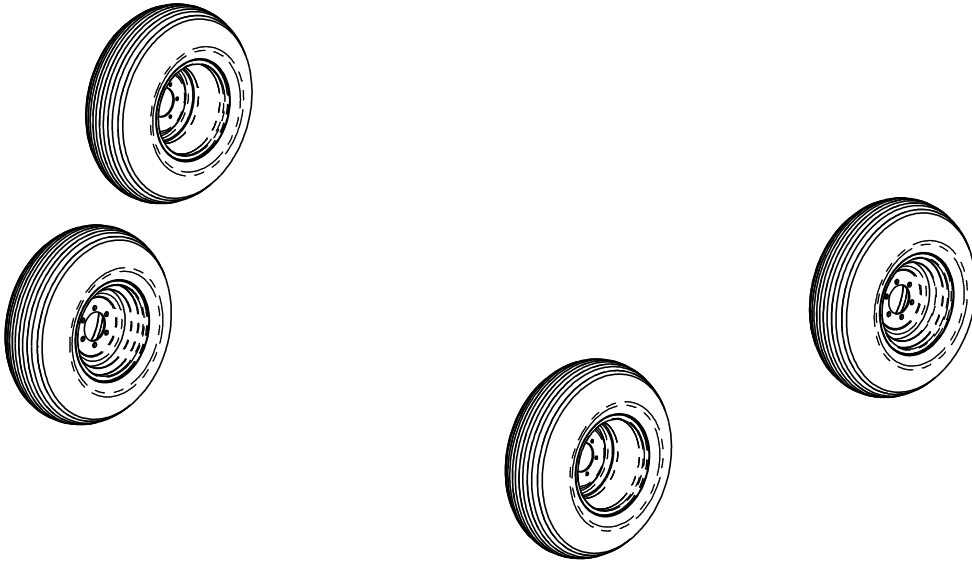

#	P. NUMBER	DESCRIPTION	QTY
1	03004	TIRE AND WHEEL 12.5L-15	4



## Fabrication SHoule limited guarantee on agricultural and commercial equipment

Fabrication SHoule Inc guarantees every new farm and commercial product of the manufacturer SHoule against any defect of material and manufacturing, within the framework of a normal use, during one year after the date of retail purchase SHoule will guarantee its product for (1) year, on parts and imperfection of manufacturing This Limited

Guarantee will apply only to equipments made by S.Houle

**EQUIPMENT AND ACCESSORIES WHICH ARE NOT MADE BY S HOULE ARE GUARANTEED ONLY IN THE MEASURE WHICH THE GUARANTEE OF THE ORIGINAL MANUFACTURER DETERMINES AND APPROVES THAT THERE IS A MANUFACTURING DEFECT**

During the period limited by guarantee indicated above, any defect in the material (equipment) or in the manufacturing of any equipment fabricated by S.Houle will be repaired or replaced without responsibility by an authorized independent retailer. An authorized retailer has to make the repair under guarantee or the replacement of parts. The costs of labour must be approved by manufacturing SHoule before beginning (undertaking) the works otherwise these could be totally refused, according to the politics (policy) of working refund (repayment) of S.Houle. SHoule reserves the right to supply parts, for replacement which he (it) considers appropriate.

**RESPONSIBILITY OF THE BUYER:** This limited guarantee requires (demands) the appropriate maintenance and the overhauls of the agricultural or commercial equipment such as indicated in operator manual supplied with the new equipment. The cost of the regular maintenance or the required services is the responsibility of the buyer. The buyer has to keep his invoices which prove that the maintenance was made.

The limited guarantee may be revoked (dismissed) by Fabrication S.Houle if the above mentioned conditions (requirements) are not respected.

### EXCLUSIONS AND LIMITATIONS

Guarantees WILL NOT APPLY on:

- 1 Any defect which was caused (according to the judgment of SHoule by a use other than that normally planned, or by the following causes: (i) accident (ii) a misuse or a carelessness (negligence) (iii) excessive use (iiii) lack of reasonable and appropriate maintenance, (v) incorrect repair or bad installation (vi) or when warehoused (stored away) (vii) modification not authorized by SHoule (viii) natural disasters (ix) vandalism (x) parts, or accessories installed on the equipment which were not made or not installed by the authorized retailer (xi) elements (xii) collision or accidents
- 2 Any agricultural or commercial equipment which the identification number or serial number or the trade names were changed or removed
- 3 Any agricultural or commercial equipment on services of which the required or recommended overhaul were executed by using parts not made, approved or supplied by SHoule or not meeting the specifications, but without limitation, lubricants (oil, grease) and liquids for hydraulics
- 4 The equipment used for rental, industrial work, construction or if the equipment is used for a purpose other than the application in which it was designated (design) for by SHoule
- 5 Any equipment used for field demonstrations by a retailer not approved by S.Houle. The guarantee will be to the discretion of S.Houle or any other demonstration
- 6 Any defect which was caused (according to the judgment of S.Houle) by the operation of the equipment without submitting itself to the standard (in the standard) procedures of exploitation (operation) described in operator manual
- 7 The guarantee on tires is the responsibility of the manufacturer of the respective product
- 8 Cost of the transport, if necessary, to transport to the retailer S.Houle
- 9 In no case the responsibility of S.Houle can exceed the cost of the product
- 10 SHoule will be subjected in no circumstances to compensate, whoever it is, for the loss of income for a discontinued equipment, for a time of the repairs no matter the reason for this breakdown.
- 11 The costs of estimation or the diagnostic and the overtime of work for the repair are not covered under this limited guarantee policy.
- 12 The depreciation caused by the normal wear, the lack of reasonable and appropriate maintenance, the misuse, and/or the lack of protection during warehousing
- 13 Accessories and electronic components which are not of or from S.Houle are guaranteed only under the limited guarantee by this manufacturer.
- 14 Articles of wear which are registered by the group of products below:

Normal wear parts: flow divider, wear plates, the bolts, the nuts, spring blades, the swivel skid shoe, the special bolts of swivelling skid shoe, slide channels, chains and chain attachments, cast iron shoe, hydraulic hoses, swivel, clutch and their components, the gear box, the shaft, ...

**EXCLUSION FROM GUARANTEES:** SHOULE RESERVES THE RIGHT TO MODIFY, TO CHANGE AND TO IMPROVE THEIR PRODUCTS WITHOUT INCURRING ANY OBLIGATION TO REPLACE PRODUCTS PREVIOUSLY SOLD WITH SUCH A MODIFICATION. NO PERSON IS AUTHORIZED TO GIVE ANOTHER GUARANTEE, OR TO ASSUME ANY ADDITIONAL OBLIGATION ON EQUIPMENTS MADE BY S.HOULE.





**Fabrication S.Houle inc.**

300 Industrial blvd. P.O. box 750  
St-Germain-de-Grantham, Quebec, Canada, J0C 1K0  
Phone : 819 395-4380 Fax. : 819 395-5516  
Toll free : 1 888-404-4380  
E-Mail : info@shoule.com Web : www.shoule.com

**Product Registration**

**Dealer instructions:**  
Make sure registration is complete and signed.

**Product Information :**

MACHINE MODEL : \_\_\_\_\_ DELIVERY DATE : \_\_\_\_\_ / \_\_\_\_\_ / \_\_\_\_\_  
mm dd yyyy  
SERIAL NUMBER : \_\_\_\_\_  
OPTIONAL EQUIPMENT : \_\_\_\_\_

**Customer Information :**

FIRST & LAST NAME : \_\_\_\_\_ PHONE : \_\_\_\_\_  
MAILING ADDRESS : \_\_\_\_\_ EMAIL : \_\_\_\_\_  
Civic number and street  
City  
State / Province Zip Code

**Dealer Information :**

DEALER NAME : \_\_\_\_\_ PHONE : \_\_\_\_\_  
MAILING ADDRESS : \_\_\_\_\_ EMAIL : \_\_\_\_\_  
Civic number and street  
City  
State / Province Zip Code

**Signatures :**

\_\_\_\_\_  
Owner or designated representative signature  
\_\_\_\_\_  
Authorized dealer signature  
**Note : Both dealer and owner must sign in order to validate the warranty.**

**I hereby acknowledge that:**

- |  |  |
|--|--|
| <ol style="list-style-type: none"><li>1. I have received and accepted delivery of equipment described.</li><li>2. The equipment was checked thoroughly for loose or missing parts and has been adjusted in accordance with the pre-delivery checklist.</li><li>3. I have been provided with and have carefully read the instruction manual.</li><li>4. I have read and understand the nature and extent of the warranty and understand clearly that there were and are no other representations or warranties, either express or implied, made by anyone.</li><li>5. A copy of the present document must be completed and transmitted to Fa-</li></ol> | <ol style="list-style-type: none"><li>6. brication S.Houle as soon as possible, in order to process your warranty.</li><li>6. I have been advised on proper operation, maintenance and lubrication procedures of this equipment.</li><li>7. I have been instructed on and do understand the application, limitations and capacities this equipment was designed and recommended for, all as described in the Instruction Manual and other literature published by Fabrication S.Houle inc.</li></ol> |
|--|--|

ONE YEAR WARRANTY COVER PARTS ONLY, EFFECTIVE WHEN THIS FORM HAS ALL APPLICABLE INFORMATION COMPLETED, IS SIGNED BY BOTH THE OWNER AND THE DEALER AT THE TIME OF DELIVERY, THEN FORWARDED TO **FABRICATION S.HOULE INC.** WARRANTY SERVICE MAY BE DENIED IF THIS FORM CONTAINS FALSE INFORMATION OR IS INCOMPLETE.



**Fabrication S.Houle inc.**

300 boul. Industriel, boîte postale 750  
St-Germain-de-Grantham, Québec, Canada, J0C 1K0  
Tél : 819 395-4380      Téléc. : 819 395-5516  
Sans frais : 1 888-404-4380  
Courriel : [info@shoule.com](mailto:info@shoule.com)      Site : [www.shoule.com](http://www.shoule.com)

**Fabrication S.Houle inc.**

300 Industrial blvd, C P 750  
St-Germain-de-Grantham, Québec, Canada, J0C 1K0T  
Phone : 819 395-4380      Fax. : 819 395-5516  
Toll free : 1 888-404-4380  
E-mail : [info@shoule.com](mailto:info@shoule.com)      Web : [www.shoule.com](http://www.shoule.com)